

PGP 500 pumps offer superior performance, high efficiency and low noise operation at high operating pressures. They are produced in four frame sizes (PGP 502, PGP 505, PGP 511, PGP 517) with displacements ranging from 0.8 to 70 cm³/rev. A wide variety of standard options is available to meet specific application requirements.

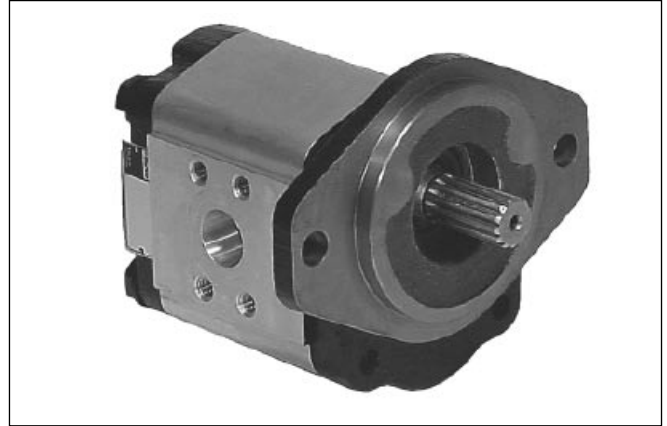

Characteristics

- **Up to 280 bar continuous operation**
High strength materials and large journal diameters provide low bearing loads for high pressure operation.
- **Low noise**
PGP 502 - 9 tooth gear profile, PGP 505 and 517 - 13 tooth gear profile, PGP 511 - 12 tooth gear profile and optimized flow metering provide reduced pressure pulsation and exceptionally quiet operation (PGP511 also available as noise reduced “stealth” version).

- **High efficiency**
Pressure balanced bearing blocks assure maximum efficiency under all operating conditions.
- **Application flexibility**
International mounts and connections, integrated valve capabilities and common inlet multiple pump configurations provide unmatched design and application versatility.
- **Large range of integrated valves**

Technical data

Pump type	Heavy-duty, aluminium, external gear.
Mounting	SAE, rectangular, thru-bolt standard specials on request.
Ports	SAE and metric split flanges and others
Shaft style	SAE splined, keyed, tapered, cylindrical tang drive, specials on request.
Speed	500 - 5000 rpm, see Technical Data
Theor. displacement	See Technical Data
Drive	Drive direct with flexible coupling is recommended.
Axial / Radial load	Units subject to axial or radial loads must be specified with an outboard bearing.
Inlet pressure	Operating range 0.8 to 2 bar abs. Min. inlet pressure 0.5 bar abs. Short time without load. Consultation is recommended.
Outlet pressure	See Technical Data
Pressure rising rate	Max. 3000 bar/s
Flow velocity	See Nomograph for Pipe Velocity
Hydraulic fluids	Hydraulic oil HLP, DIN 51524-2
Fluid temperature	Range of operating temperature -15 to +80 °C. Max. permissible operating pressure dependent on fluid temperature. Temperature for cold start -20 to -15 °C at speed ≤ 1500 rpm. Max. permissible operating pressure dependent on fluid temperature.

Fluid viscosity	Range of operating viscosity 8 to 1000 mm ² /s (511 & 517) 20 to 1000 mm ² /s (502 & 505) Max. permissible operating pressure dependent on viscosity. Viscosity range for cold start 1000 to 2000 mm ² /s at operating pressure p≤10 bar and speed n≤1500 rpm.
Range of ambient temperature	-40 °C to +70 °C
Filtration	According to ISO 4406 Cl. 18/16/13
Direction of rotation (looking at the drive shaft)	Clockwise, counter-clockwise or double. Attention! Drive pump only in indicated direction of rotation.
Multiple pump assemblies	<ul style="list-style-type: none"> • Available in two or three section configuration. • Max. shaft load must be conform to the limitations shown in the shaft loading rating table in this catalogue. • Max. load is determined by adding the torque values for each pumping section that will be simultaneously loaded.
Separate or common inlet capability	Separate inlet configuration: <ul style="list-style-type: none"> • Each gear housing has individual inlet and outlet ports. Common inlet configuration: <ul style="list-style-type: none"> • Two gear sets share a common inlet.

PI PGP-PGM UK.PMD RH





Gear design

Type

Unit

**Dis-
placement**

Rotation

Shaft

Flange

Shaft seal

Inlet side ports option

Outlet

No rear ports
(rear ports on request)

Code	Type
P	Pump

Code	Unit
	Pump
A	Single unit
B	Multiple unit

Displacement	
Code	ccm
0008	0.8
0012	1.2
0016	1.6
0021	2.1
0025	2.5
0033	3.3
0036	3.6
0043	4.3
0048	4.8
0058	5.8
0062	6.2
0079	7.9

Code	Rotation
C	Clockwise
A	Counter-clockwise

Code	Shaft
H1 ²⁾	Ø10, 3.0 key, no thread, 36L, parallel
P2 ³⁾	Ø9.35, 8.8L, 2.4 key, M6, taper 1:8
V1 ⁴⁾	5x6.5 long shaft w/o coupling tang drive
V2 ⁵⁾	5x4.5 short shaft w/o coupling tang drive

Code	Port options
E3E2	1/2" - 14 BSP thread/ 3/8" - 19 BSP thread
J4J3	Ø12 mm - Ø30 mm - M6 square flange/ Ø8 mm - Ø30 mm - M6 square flange

Example: E3 = inlet port
E2 = outlet port

Code	Shaft seal
X	No seal
N	NBR

Code	Flange
D1	52.2x72.0 - Ø25.4 rectangular
H1	82.5 - Ø50.8 SAE "A-A" 2 bolt flange
P3	40.0x40.0 - Ø32.0 w/ seal, thrubolt flange
P4	40.0x40.0 - Ø32.0 w/ seal f. short shaft, thrubolt flange

²⁾ Only used with flange H1, D1.

³⁾ Only used with flange D1.

⁴⁾ Only used with flange H1.

⁵⁾ Only used with flange P3, P4.

PGP502 - 0.8 CC

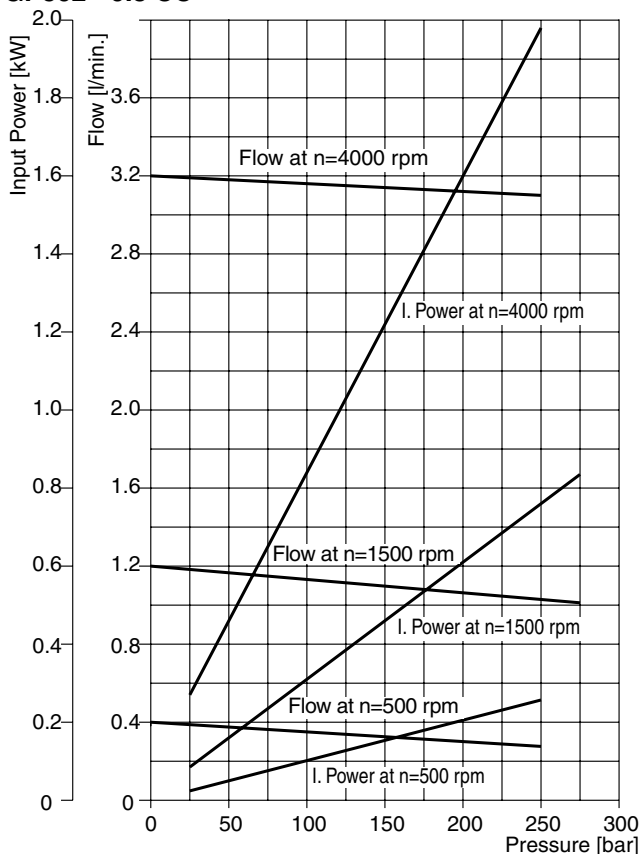

PGP502 - 2.1 CC

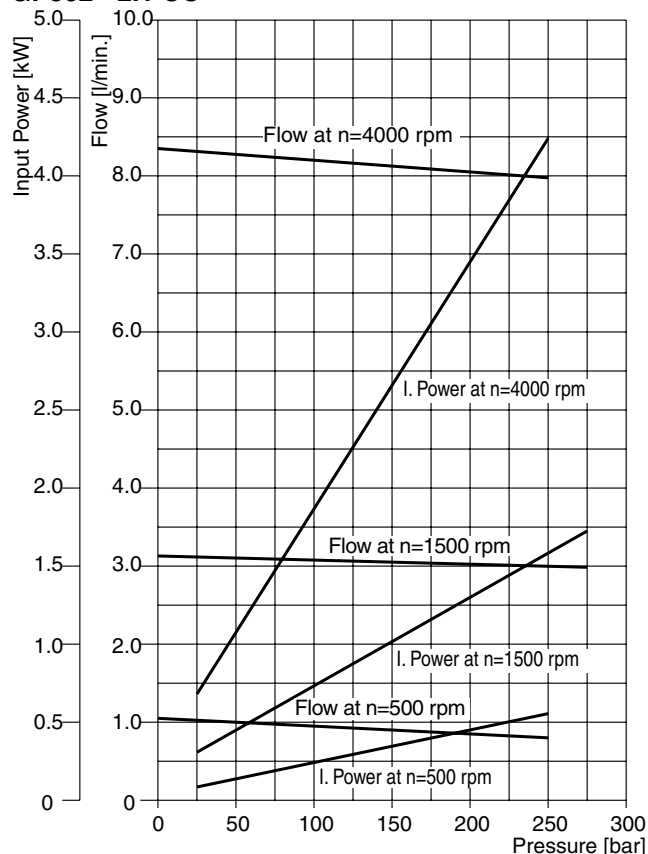

PGP502 - 3.6 CC

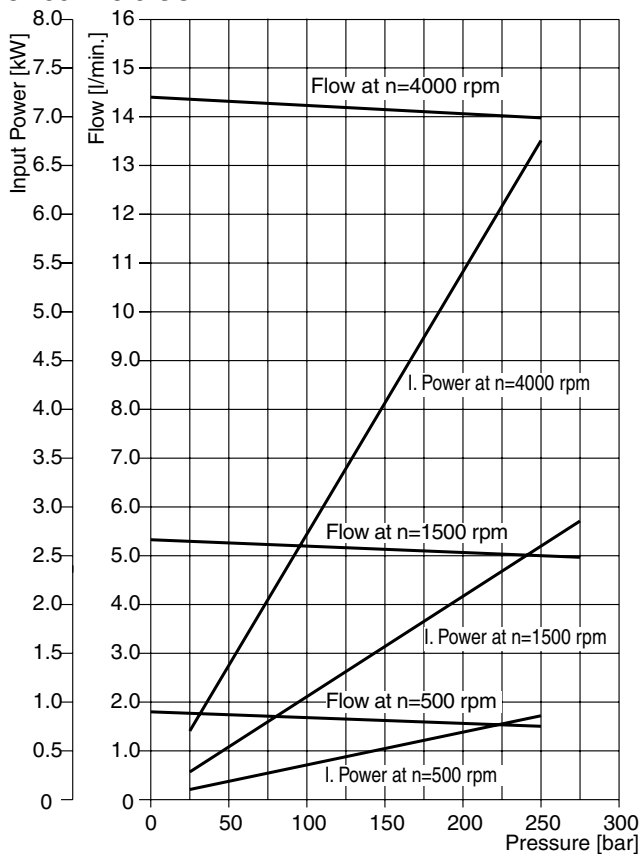

PGP502 - 6.2 CC

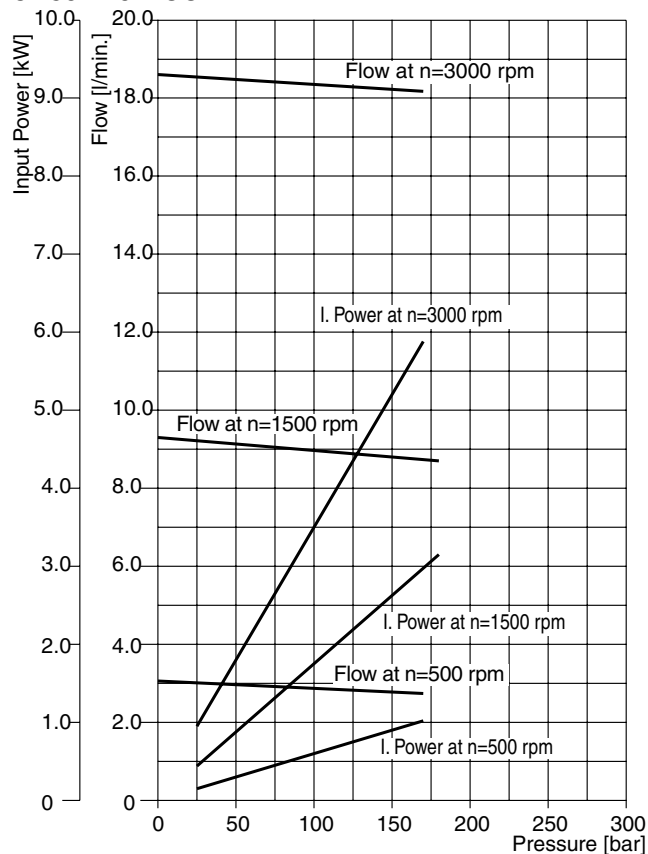

PI PGP-PGM UK.PMD RH

Fluid temperature: 45 °C ± 2K ;

Viscosity: 36mm²/s ;

Inlet pressure: 0.9 + 0.1 bar absolute





PG
 Gear design

Type

Unit

**Dis-
 placement**

Rotation

Shaft

Flange

Shaft seal

**Inlet
 side ports
 option**

**Outlet
 side ports
 option**

B 1 B 1

No rear ports
 (rear ports on request)

Code	Type
P	Pump

Code	Unit Pump
A	Single unit
M	Single distributor unit
B	Multiple unit

Displacement	
Code	ccm
0030	3.0
0040	4.0
0060	6.0
0080	8.0
0100	10.0
0120	12.0

Code	Rotation
C	Clockwise
A	Counter-clockwise

Code	Shaft
A1 ²⁾	9T, 16/32DP, 32L, SAE "A" spline
J1 ²⁾	Ø12.7, 3.2 key, no thread, 38L, parallel
K1 ³⁾	Ø15.88, 4.0 key, no thread, 32L, SAE "A", parallel
Q2 ⁴⁾	Ø14.25, 5.5L, 3.0key, M10x1, taper 1:8

Code	Port options
E5E3	3/4" - 14 BSP thread/ 1/2" - 14 BSP thread
J7J5	Ø20 mm - Ø40 mm - M6 square flange/ Ø15 mm - Ø35 mm - M6 square flange

Example: J7 = inlet port
 J5 = outlet port

Code	Shaft seal
X	No seal
N	NBR

Code	Flange
D2 ⁵⁾	56.0x73.0 - Ø30.0 rectangular
H1	82.5 - Ø50.8 SAE "A-A" 2 bolt flange
H2 ⁶⁾	106.4 - Ø82.55 SAE "A" 2 bolt flange

⁵⁾ Only used with ports J*J*.
⁶⁾ Only used with ports E*E*.

²⁾ Only used with flange H1, H2.
³⁾ Only used with flange H2.
⁴⁾ Only used with flange D2.

PGP505 - 3.0 CC

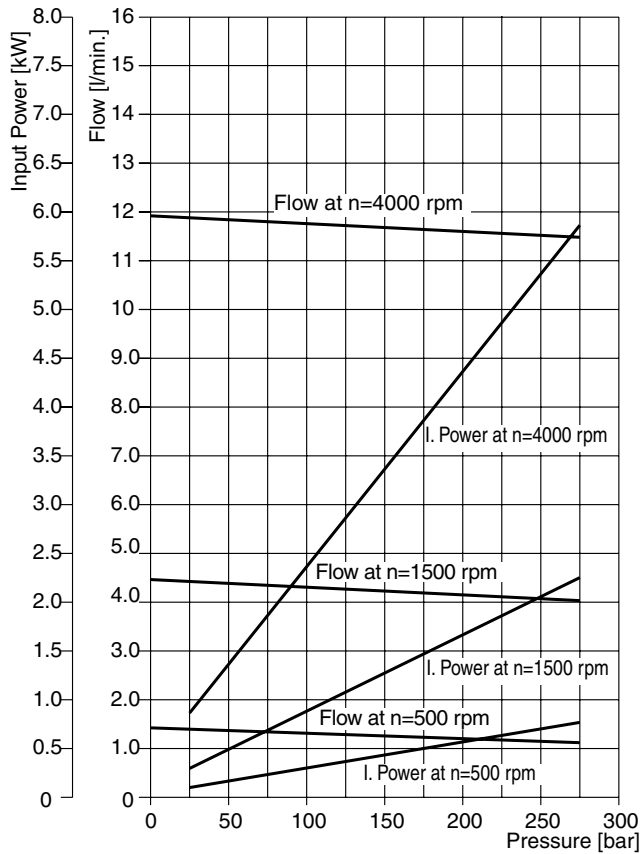

PGP505 - 6.0 CC

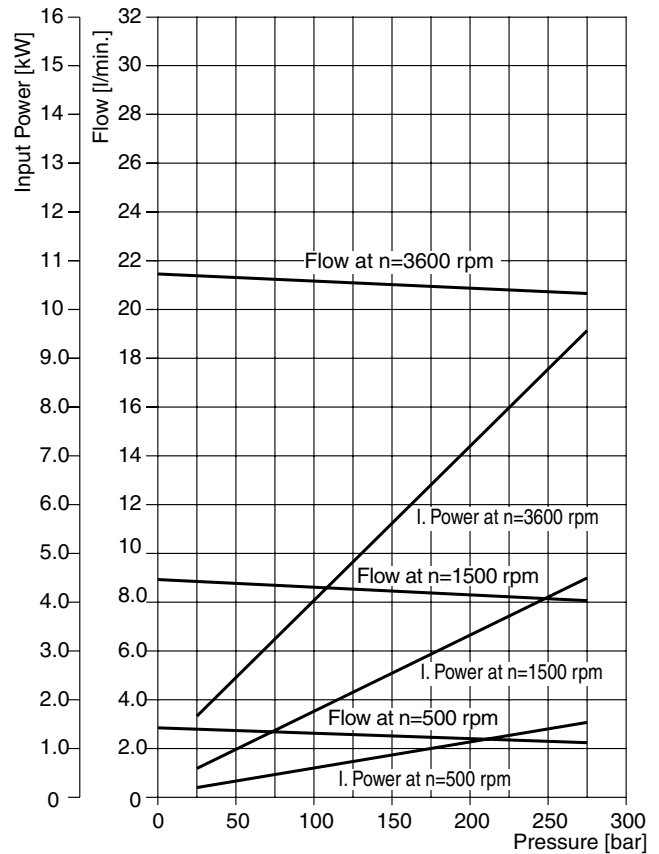

PGP505 - 10.0 CC

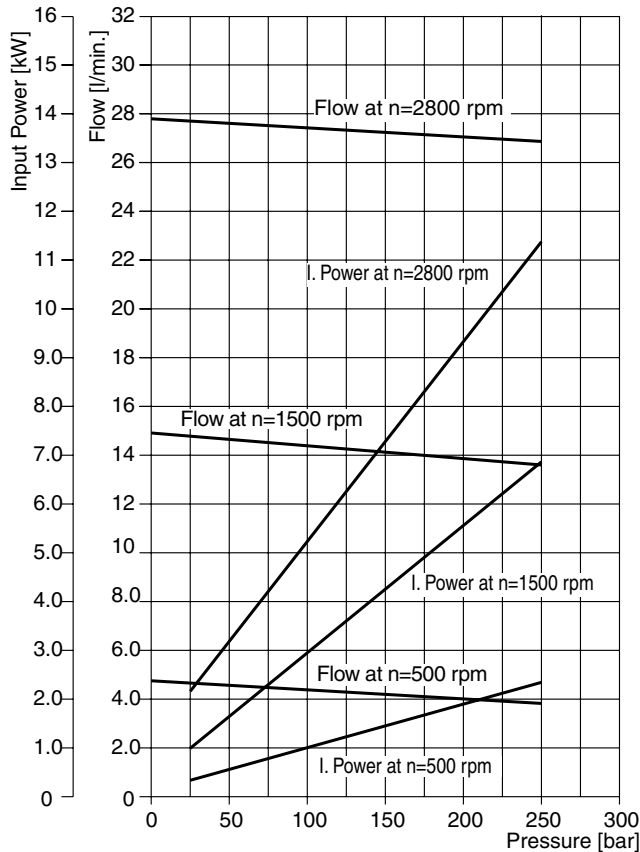

PGP505 - 12.0 CC

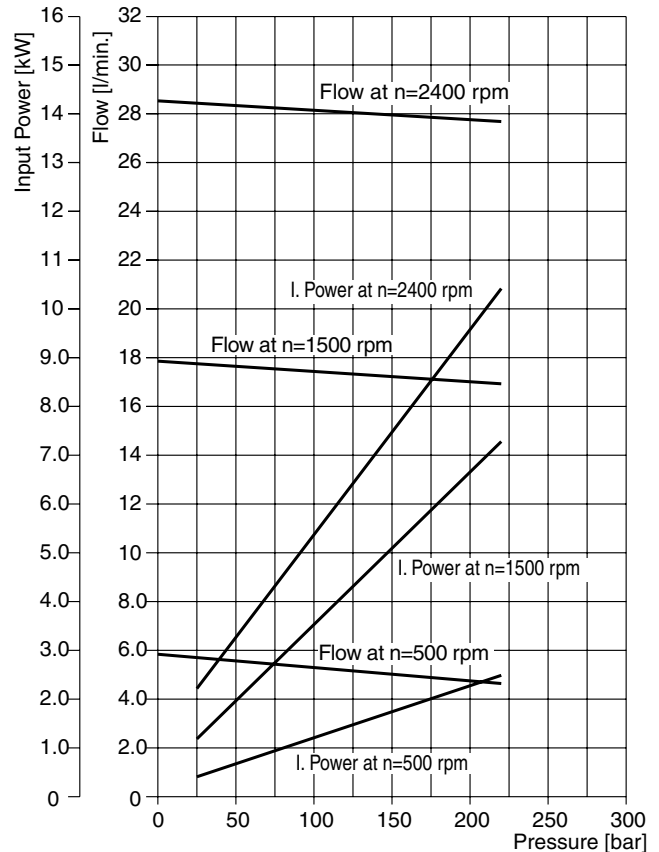

PI PGP-PGM UK.PMD RH Fluid temperature: 45 °C ± 2K ; Viscosity: 36mm²/s ; Inlet pressure: 0.9 + 0.1 bar absolute



PGP505 A XXXX Y A1 H2 N SS PP B1 B1

“Y” = C (clockwise rotation)
 = A (counter-clockwise rotation)

Displacement XXXX	cm ³ /rev	Dimension			Inlet port			Outlet port			Speed of rotation		Working pressure max. bar	Order number direction of rotation	
		A	B	C	SS	G	F	PP	G	F	min. rpm	max. rpm		clockwise	counter-clockwise
0030	3.0	35.9	41.1	79.8	E5	3/4"-14 BSP	42.0	E3	1/2"-14 BSP	34.0	500	4000	275	331 9111 385	
0040	4.0	37.2	43.8	79.8	E5	3/4"-14 BSP	42.0	E3	1/2"-14 BSP	34.0	500	4000	275	331 9111 386	
0060	6.0	39.8	49.1	84.8	E5	3/4"-14 BSP	42.0	E3	1/2"-14 BSP	34.0	500	3600	275	331 9111 387	
0080	8.0	42.5	54.5	89.8	E5	3/4"-14 BSP	42.0	E3	1/2"-14 BSP	34.0	500	3000	275	331 9111 383	331 9112 136
0100	10.0	45.2	59.8	100.8	E5	3/4"-14 BSP	42.0	E3	1/2"-14 BSP	34.0	500	2800	250	331 9111 388	
0120	12.0	47.9	65.2	104.8	E5	3/4"-14 BSP	42.0	E3	1/2"-14 BSP	34.0	500	2400	220	331 9111 389	

Dimensions (clockwise rotation shown)

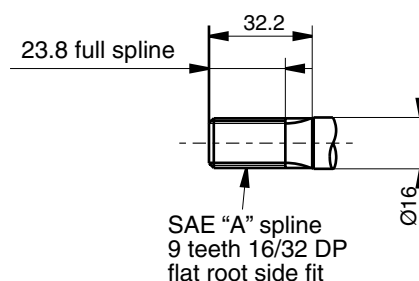
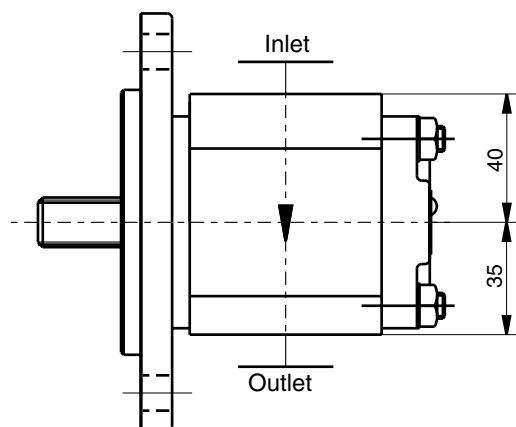
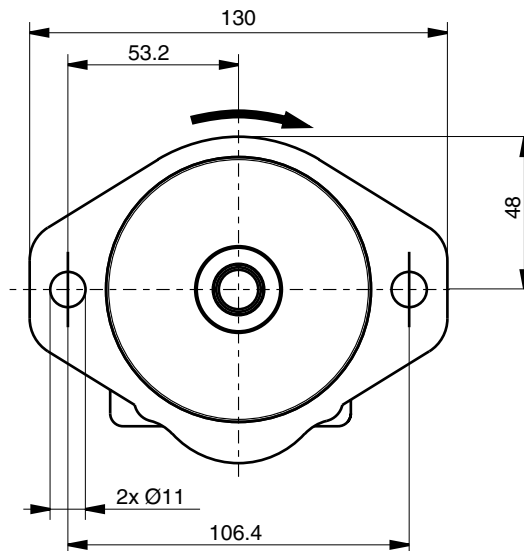
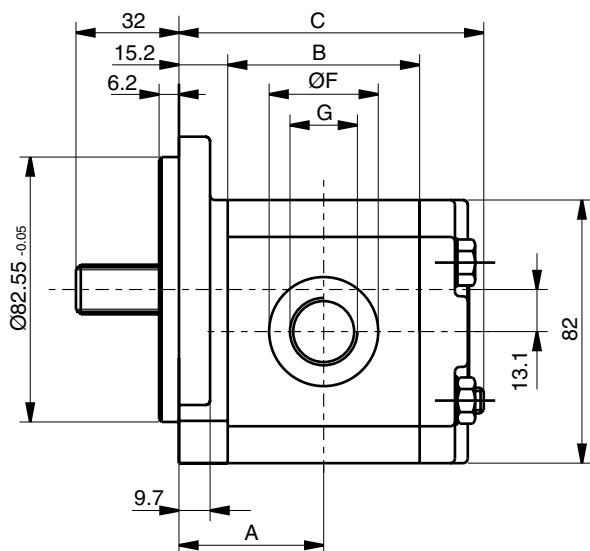
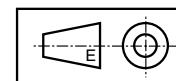

PGP505 A XXXX Y Q2 D2 N SS PP B1 B1

“Y” = C (clockwise rotation)
 = A (counter-clockwise rotation)

Displacement		Dimension			Inlet port			Outlet port			Speed of rotation		Working pressure	Order number direction of rotation			
XXXX	cm ³ /rev	A	B	C	SS	d	D	G	PP	d	D	G	min. rpm	max. rpm	max. bar	clockwise	counter-clockwise
0030	3.0	35.9	41.1	74.3	J7	20.0	40.0	M6	J5	15.0	35.0	M6	500	4000	275	331 9111 334	
0040	4.0	37.2	43.8	76.4	J7	20.0	40.0	M6	J5	15.0	35.0	M6	500	4000	275	331 9111 039	331 9112 061
0060	6.0	39.8	49.1	81.7	J7	20.0	40.0	M6	J5	15.0	35.0	M6	500	3600	275	331 9111 040	331 9112 077
0080	8.0	42.5	54.5	87.1	J7	20.0	40.0	M6	J5	15.0	35.0	M6	500	3000	275	331 9111 041	331 9112 078
0100	10.0	45.2	59.8	92.4	J7	20.0	40.0	M6	J5	15.0	35.0	M6	500	2800	250	331 9111 087	331 9112 033
0120	12.0	47.9	65.2	97.8	J7	20.0	40.0	M6	J5	15.0	35.0	M6	500	2400	220	331 9111 246	331 9112 135

Dimensions (clockwise rotation shown)

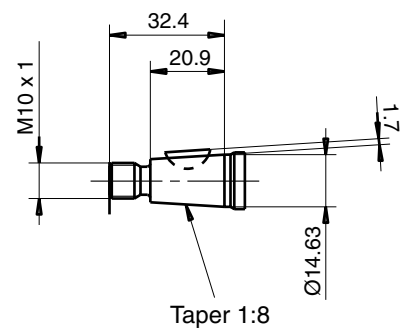
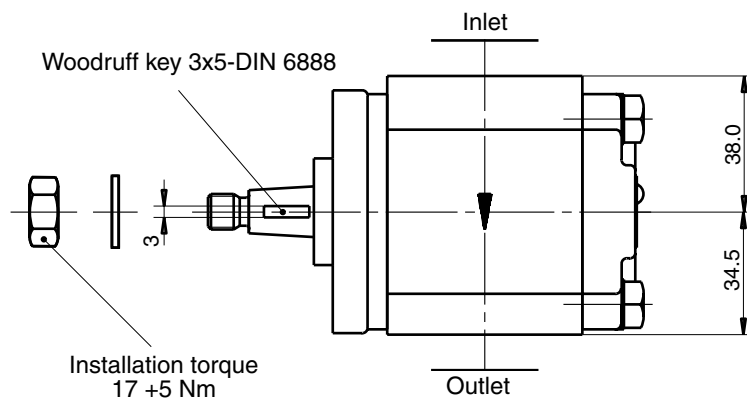
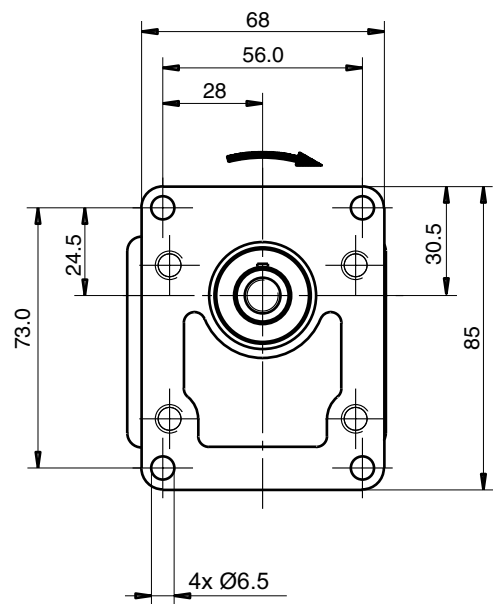
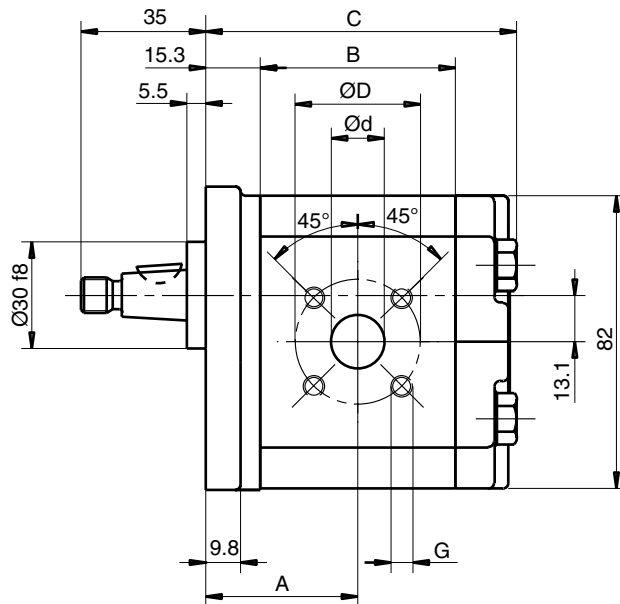
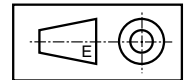

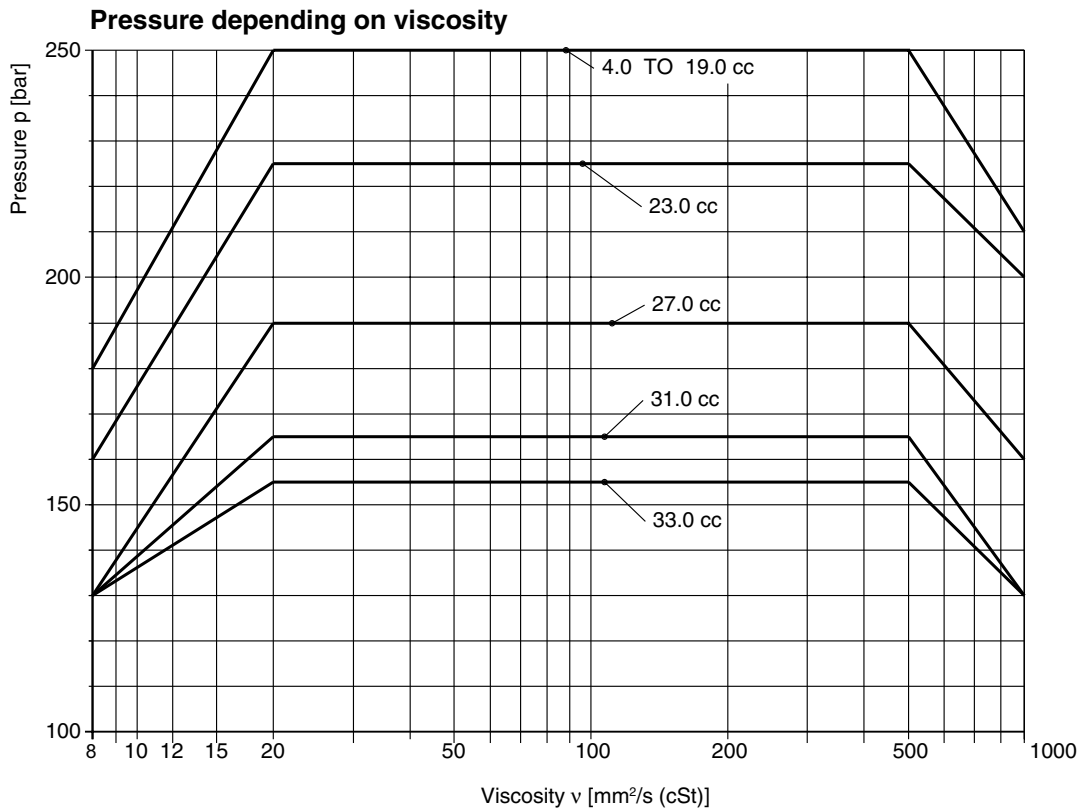
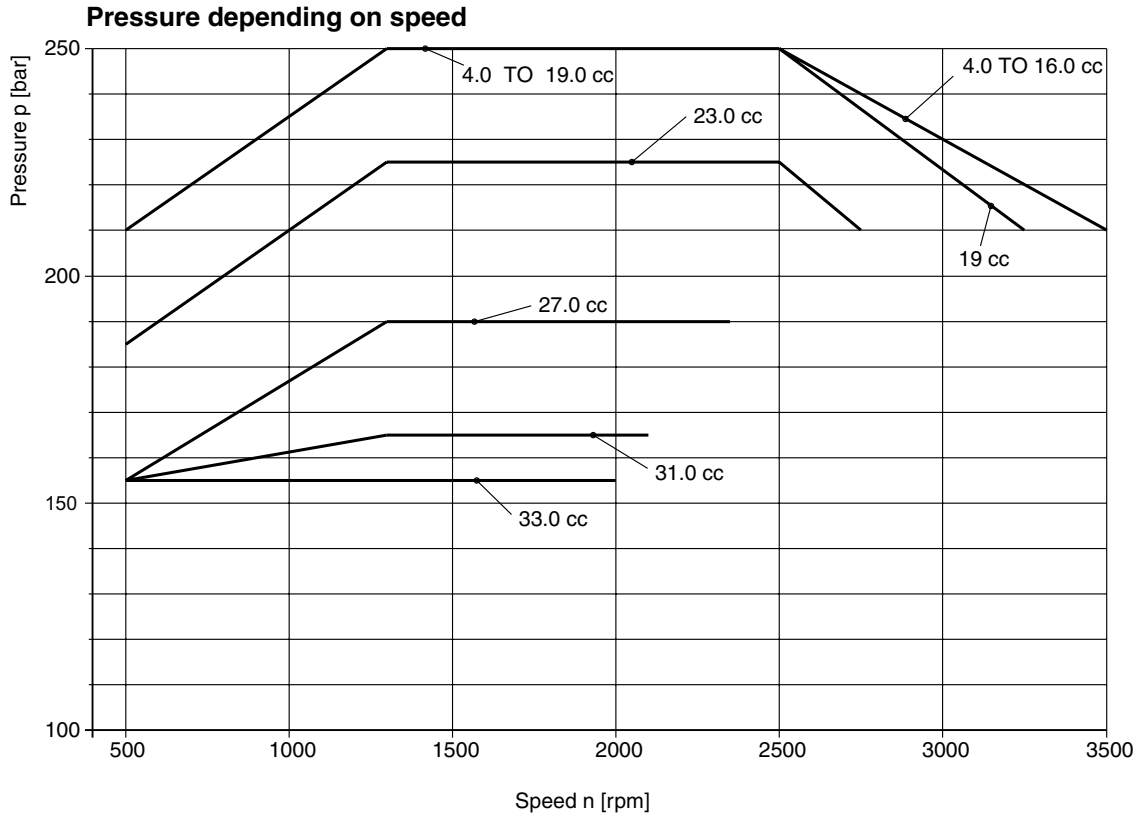

PGP511 - 6.0 CC

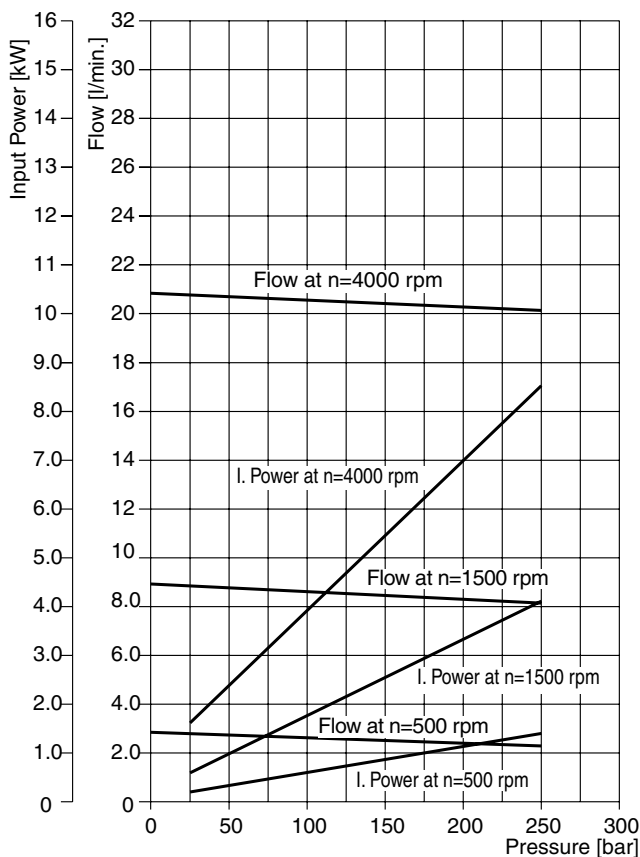

PGP511 - 10.0 CC

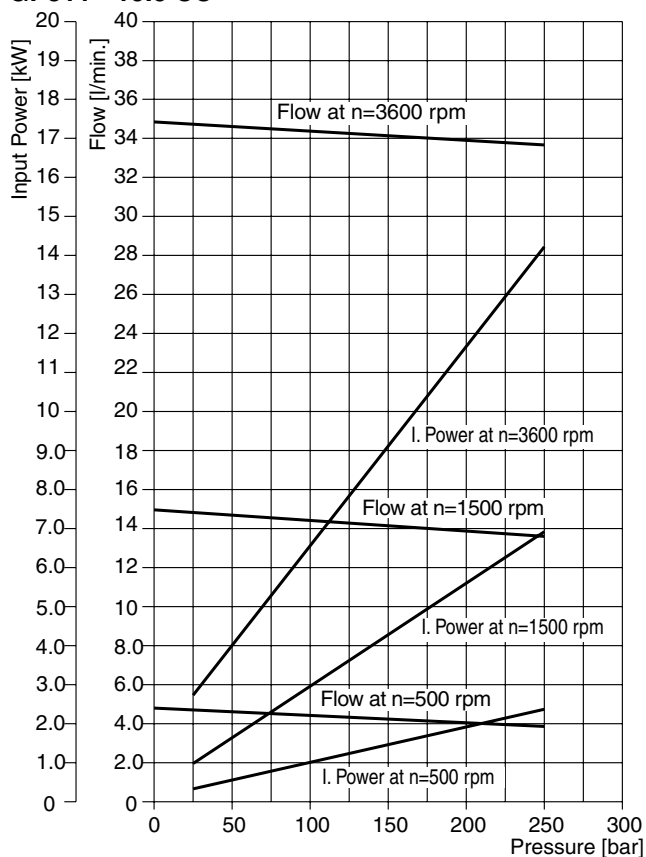

PGP511 - 19.0 CC

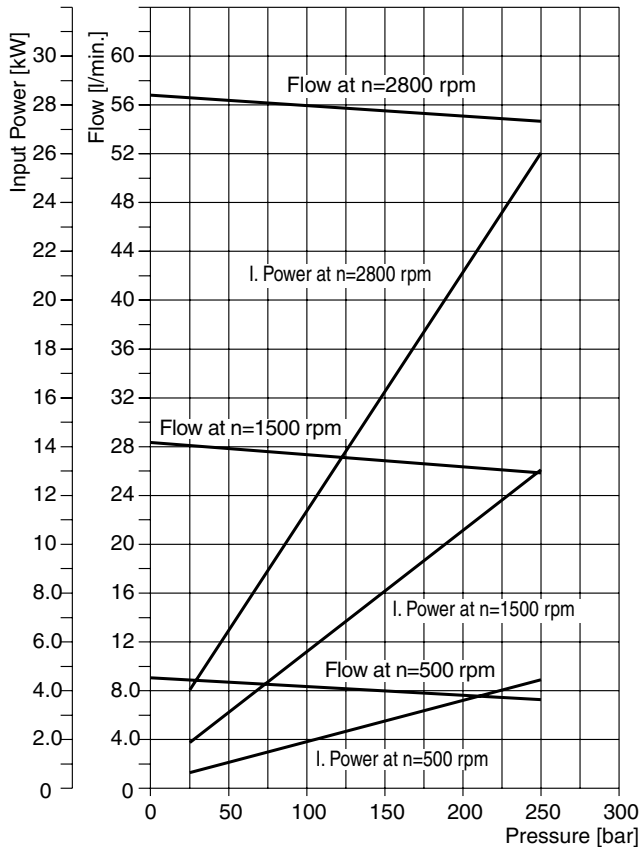

PGP511 - 33.0 CC

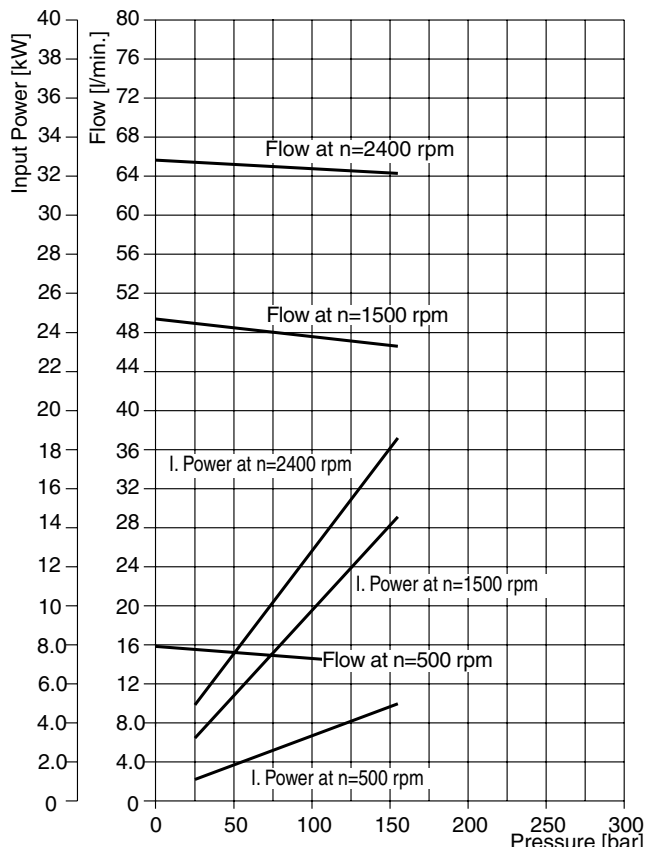

PI PGP-PGM UK.PMD RH

Fluid temperature: 45 °C ± 2K ; Viscosity: 36mm²/s ;

Inlet pressure: 0.9 + 0.1 bar absolute



PGP511 A XXXX Y A1 H2 N SS PP B1 B1

“Y” = C (clockwise rotation)
 = A (counter-clockwise rotation)

Displacement		Dimension			Inlet port			Outlet port			Speed of rotation		Working pressure max. bar	Order number direction of rotation	
XXXX	cm ³ /rev	A	B	C	SS	G	F	PP	G	F	min. rpm	max. rpm		clockwise	counter-clockwise
0040	4.0	42.6	47.0	86.7	E5	3/4"-14 BSP	42.0	E3	1/2"-14 BSP	34.0	500	3500	250		
0060	6.0	44.1	50.1	89.8	E5	3/4"-14 BSP	42.0	E3	1/2"-14 BSP	34.0	500	3500	250	334 9111 044	334 9112 621
0080	8.0	45.7	53.3	93.0	E5	3/4"-14 BSP	42.0	E3	1/2"-14 BSP	34.0	500	3500	250	334 9111 562	334 9112 622
0100	10.0	47.3	56.5	96.1	E5	3/4"-14 BSP	42.0	E3	1/2"-14 BSP	34.0	500	3500	250	334 9111 130	334 9112 628
0110	11.0	48.1	58.0	97.7	E5	3/4"-14 BSP	42.0	E3	1/2"-14 BSP	34.0	500	3500	250	334 9111 039	334 9112 023
0140	14.0	50.4	62.8	102.4	E5	3/4"-14 BSP	42.0	E3	1/2"-14 BSP	34.0	500	2700	250	334 9111 563	334 9112 623
0160	16.0	52.0	65.9	105.6	E6	1"-11 BSP	50.0	E5	3/4"-14 BSP	42.0	500	3500	250	334 9111 092	334 9112 060
0190	19.0	54.4	70.6	110.3	E6	1"-11 BSP	50.0	E5	3/4"-14 BSP	42.0	500	3200	250	334 9111 193	334 9112 624
0230	23.0	57.5	76.9	116.6	E6	1"-11 BSP	50.0	E5	3/4"-14 BSP	42.0	500	2700	210	334 9111 564	
0270	27.0	60.7	83.2	122.9	E6	1"-11 BSP	50.0	E5	3/4"-14 BSP	42.0	500	2300	180	334 9111 942	334 9112 494
0310	31.0	63.8	89.5	129.2	E6	1"-11 BSP	50.0	E5	3/4"-14 BSP	42.0	500	2000	160	334 9111 207	334 9112 229
0330	33.0	65.4	92.6	132.3	E6	1"-11 BSP	50.0	E5	3/4"-14 BSP	42.0	500	1800	150		334 9112 773

Dimensions (clockwise rotation shown)

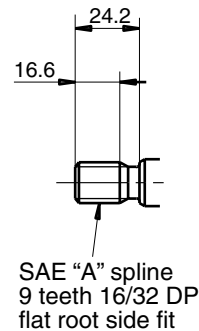
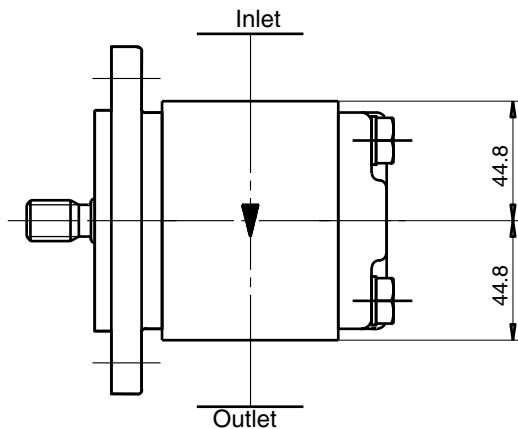
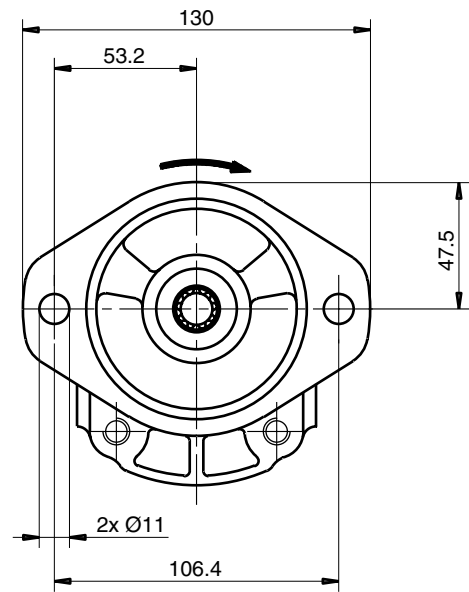
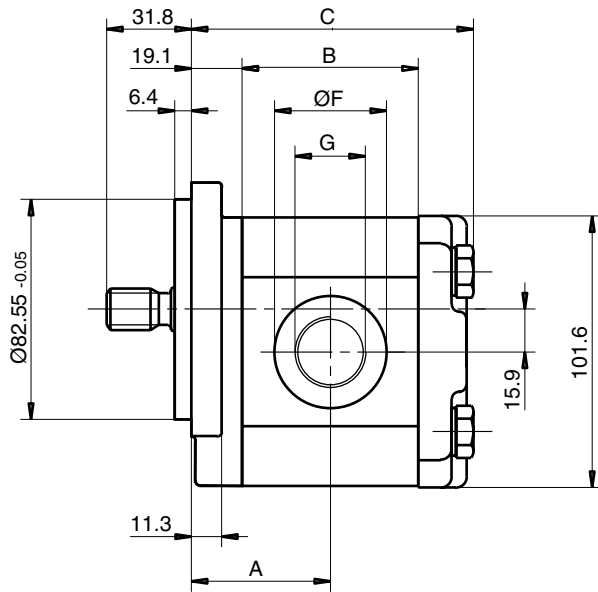
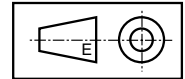

PGP511 A XXXX Y S1 D4 N SS PP B1 B1

“Y” = C (clockwise rotation)
 = A (counter-clockwise rotation)

Displacement XXXX	cm ³ /rev	Dimension			Inlet port				Outlet port				Speed of rotation		Working pressure max. bar	Order number direction of rotation	
		A	B	C	SS	d	D	G	PP	d	D	G	min. rpm	max. rpm		clockwise	counter-clockwise
0040	4.0	42.6	47.0	86.7	J7	20	40	M6	J5	15	35	M6	500	3500	250	334 9111 149	334 9112 289
0060	6.0	44.1	50.1	89.8	J7	20	40	M6	J5	15	35	M6	500	3500	250	334 9111 465	334 9112 298
0080	8.0	45.7	53.3	93.0	J7	20	40	M6	J5	15	35	M6	500	3500	250	334 9111 151	334 9112 291
0100	10.0	47.4	56.5	96.1	J7	20	40	M6	J5	15	35	M6	500	3500	250	334 9111 466	334 9112 292
0110	11.0	48.1	58.0	97.7	J7	20	40	M6	J5	15	35	M6	500	3500	250	334 9111 152	334 9112 238
0140	14.0	50.4	62.8	102.4	J7	20	40	M6	J5	15	35	M6	500	3400	250	334 9111 153	334 9112 239
0160	16.0	52.0	65.9	105.6	J7	20	40	M6	J5	15	35	M6	500	3000	250	334 9111 154	334 9112 120
0190	19.0	54.4	70.6	110.3	J9	26	55	M8	J8	18	55	M8	500	3250	250	334 9111 970	
0230	23.0	57.5	76.9	116.6	J9	26	55	M8	J8	18	55	M8	500	2750	225	334 9111 971	
0270	27.0	60.7	83.2	122.9	J9	26	55	M8	J8	18	55	M8	500	2350	190	334 9111 972	334 9112 807
0310	31.0	63.8	89.5	129.2	J9	26	55	M8	J8	18	55	M8	500	2100	165	334 9111 526	
0330	33.0	65.4	92.6	132.3	J9	26	55	M8	J8	18	55	M8	500	2000	155	334 9111 973	

Dimensions (clockwise rotation shown)

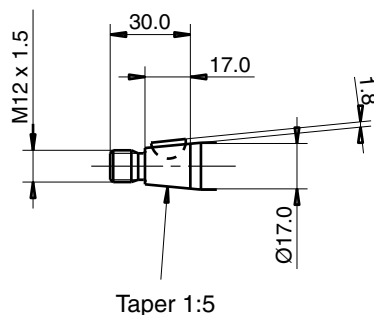
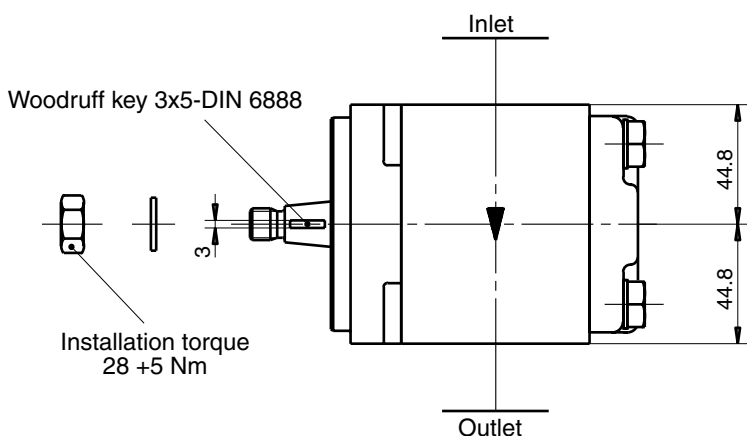
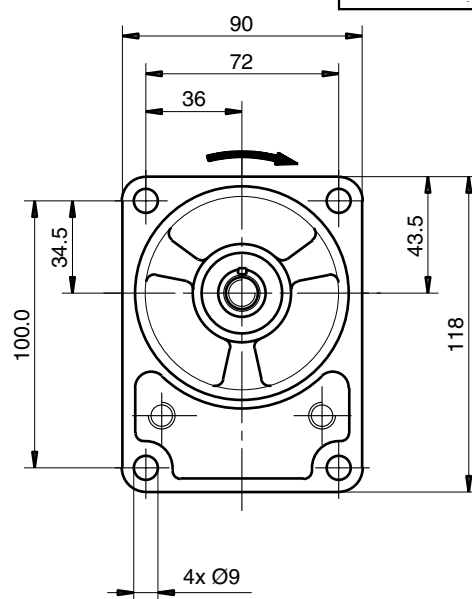
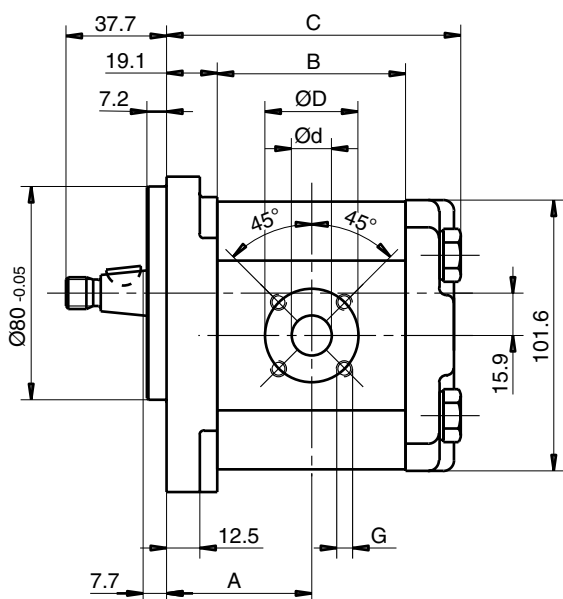
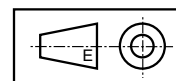

PI PGP-PGM UK.PMD RH



PGM511 A XXXX B S1 D4 N PP SS B1 B1 G4

“B” = B (bi-directional)

Displacement XXXX	cm³/rev	Dimension			Inlet port			Outlet port			Speed of rotation		Working pressure max. bar	Order number direction of rotation bi-directional		
		A	B	C	PP	d	D	G	SS	d	D	G			min. rpm	max. rpm
0060	6.0	44.1	50.1	89.8	J5	20	40	M6	J5	15	35	M6	500	3500	250	334 9219 253
0080	8.0	45.7	53.3	93.0	J5	20	40	M6	J5	15	35	M6	500	3500	250	
0100	10.0	47.3	56.5	96.1	J5	20	40	M6	J5	15	35	M6	500	3500	250	
0110	11.0	48.1	58.0	97.7	J5	20	40	M6	J5	15	35	M6	500	3500	250	
0140	14.0	50.4	62.8	102.4	J5	20	40	M6	J5	15	35	M6	500	3400	250	
0160	16.0	52.0	65.9	105.6	J5	20	40	M6	J5	15	35	M6	500	3000	250	
0190	19.0	54.4	70.6	110.3	J5	20	40	M6	J5	15	35	M6	500	3250	250	334 9219 356
0230	23.0	57.5	76.9	116.6	J5	20	40	M6	J5	15	35	M6	500	2750	225	
0270	27.0	60.7	83.2	122.9	J5	20	40	M6	J5	15	35	M6	500	2350	190	334 9219 200
0310	31.0	63.8	89.5	129.2	J5	20	40	M6	J5	15	35	M6	500	2100	165	
0330	33.0	65.4	92.6	132.3	J5	20	40	M6	J5	15	35	M6	500	2000	155	

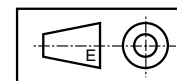

Dimensions (bi-directional motor shown)

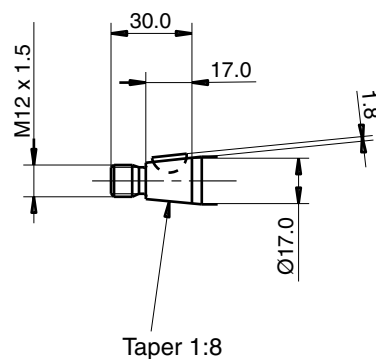
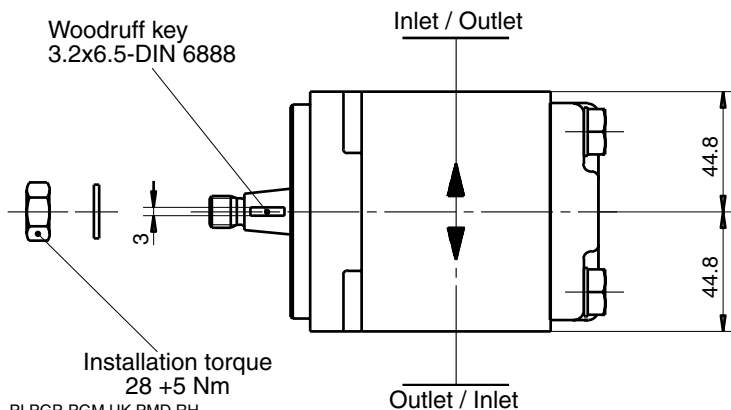
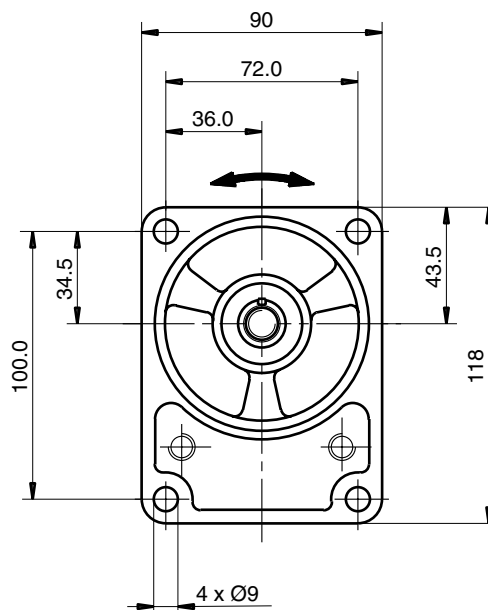
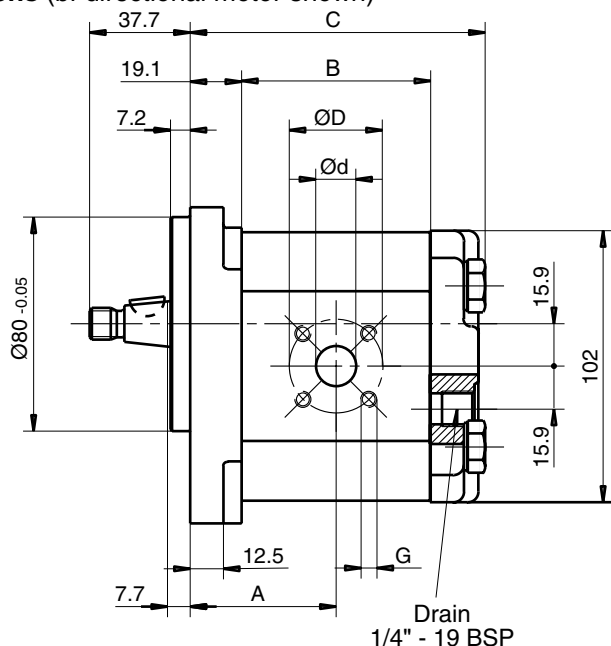

PI PGP-PGM UK.PMD RH

PG **517** **B 1 B 1**

Gear design

Type

Unit

**Dis-
placement**

Rotation

Shaft

Flange

Shaft seal

Inlet side ports option

Outlet side ports option

No rear ports
(rear ports on request)

Code	Type
P	Pump

Code	Unit
	Pump
A	Single unit
M	Single distributor unit
B	Multiple unit

Displacement	
Code	ccm
0140	14.0
0160	16.0
0190	19.0
0230	23.0
0250	25.0
0280	28.0
0330	33.0
0380	38.0
0440	44.0
0520	52.0
0700	70.0

Code	Rotation
C	Clockwise
A	Counter-clockwise

Code	Shaft
D1 ²⁾	13T, 16/32DP, 41.2L, SAE "B" spline
M1 ²⁾	Ø22.2, 6.3key, no thread, 41.2L, SAE "B", parallel
M2 ²⁾	Ø25.4, 6.3key, no thread, 46L, SAE "B-B", parallel
T1 ³⁾	Ø21.59, 11.2L, 4.0key, M14x1.5, taper 1:8

Code	Port options
E6E5	1"-11 BSP thread/ 3/4"-14 BSP thread rec. from 14 ccm to 19 ccm
E7E6	1 1/4"-11 BSP thread/ 1"-11 BSP thread rec. from 23 ccm to 38 ccm
E8E6	1 1/2"-11 BSP thread/ 1"-11 BSP thread rec. from 44 ccm to 70 ccm
J9J8	Ø26 mm-Ø55 mm-M8 square flange Ø18 mm-Ø55 mm-M8 square flange rec. from 14 ccm to 52 ccm
L3L2	Ø27 mm-Ø51 mm-M10 diamond flange Ø19 mm-Ø40 mm-M8 diamond flange rec. from 14 ccm to 52 ccm
P3P2	1"-M10 SAE metric flange 3/4"-M10 SAE metric flange rec. from 16 ccm to 23 ccm
P4P3	1 1/4"-M10 SAE metric flange 1"-M10 SAE metric flange rec. from 25 ccm to 44 ccm
P5P3	1 1/2"-M12 SAE metric flange 1"-M10 SAE metric flange rec. from 44 ccm to 70 ccm

Example: P4 = inlet port
P3 = outlet port

Code	Shaft seal
X	No seal
N	NBR
V	FPM

Code	Flange
D7	98.4x128.2 - Ø50.77 rectangular
H3	146.1 - Ø101.06 SAE "B" 2 bolt flange

²⁾ Only used with flange H3.

³⁾ Only used with flange D7.

Pressure depending on speed

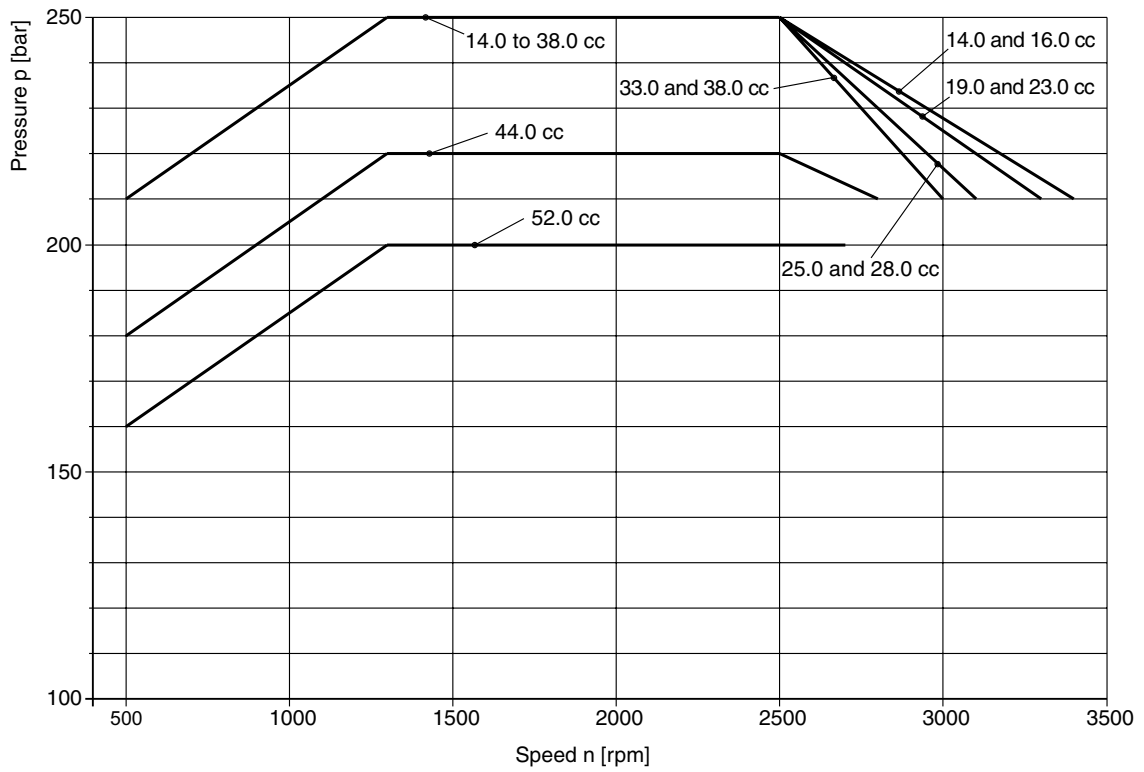

Pressure depending on viscosity

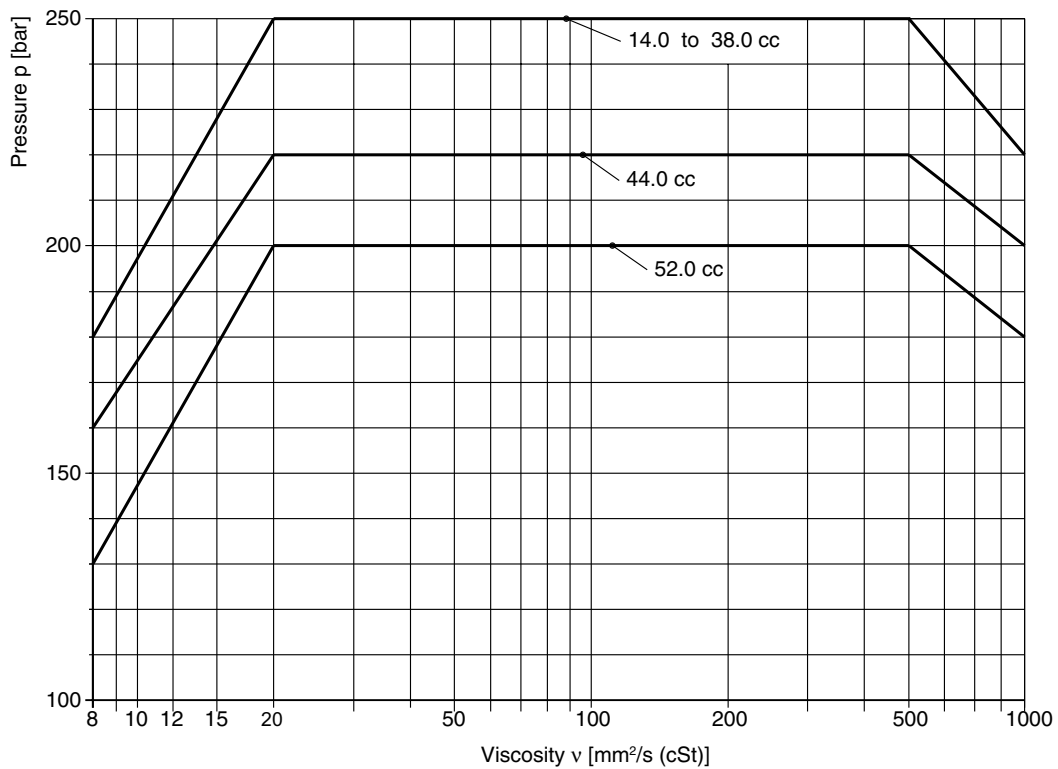

PGP517 - 14.0 CC

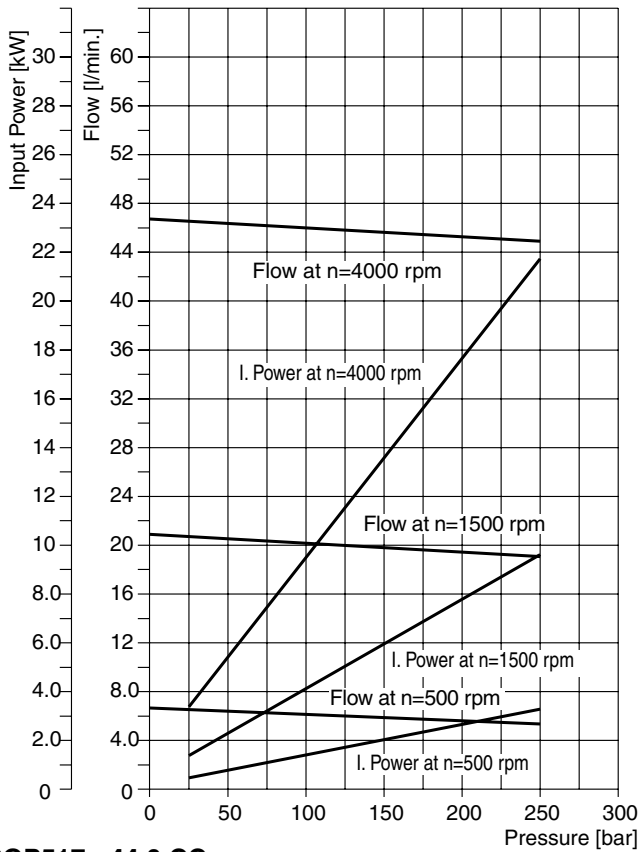

PGP517 - 25.0 CC

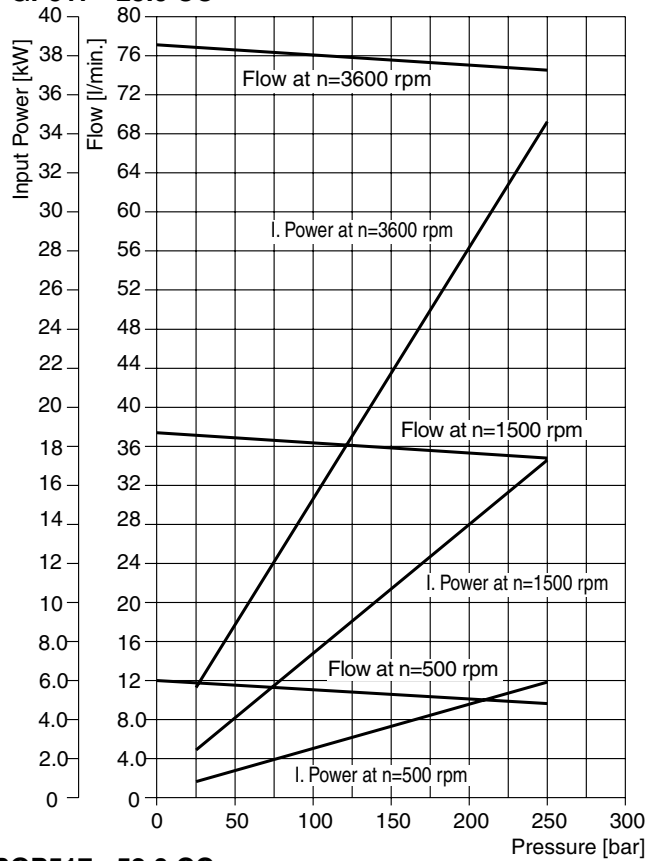

PGP517 - 44.0 CC

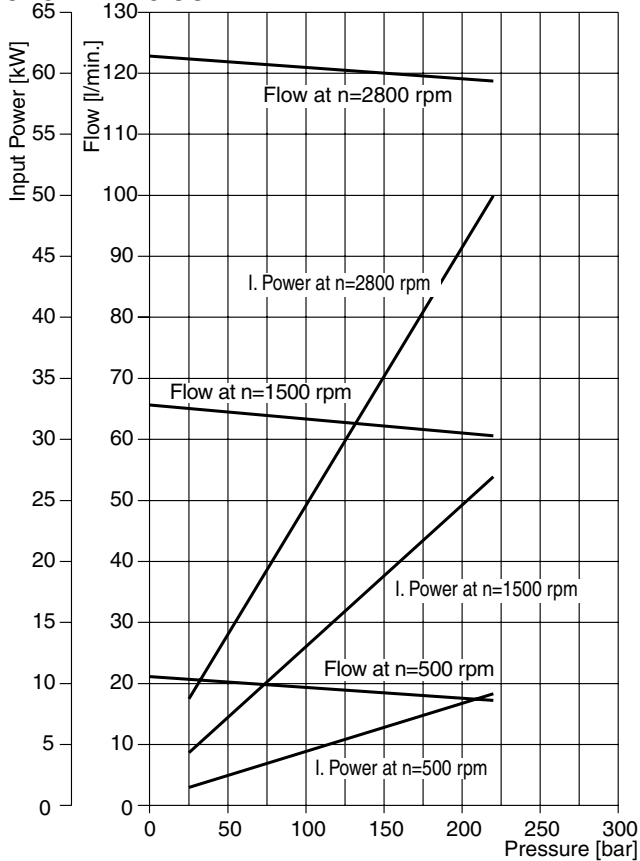

PGP517 - 52.0 CC

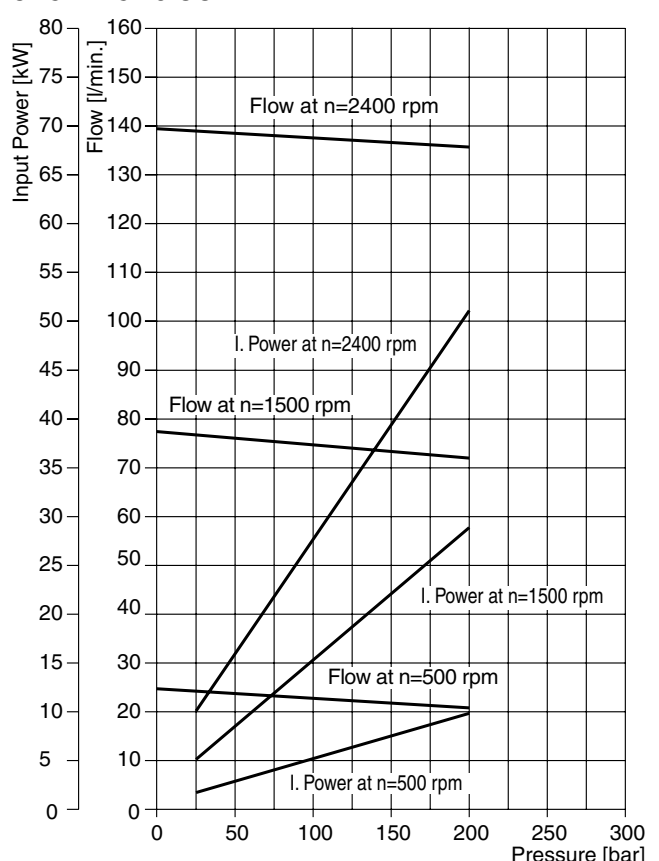

PI PGP-PGM UK.PMD RH

Fluid temperature: 45 °C ± 2K ; Viscosity: 36mm²/s ;

Inlet pressure: 0.9 + 0.1 bar absolute

PGP517 A XXXX Y D1 H3 N SS PP B1 B1

“Y” = C (clockwise rotation)
 = A (counter-clockwise rotation)

Displacement XXXX cm ³ / rev	Dimension			Inlet port					Outlet port					Speed of rotation		Working pressure max. bar	Order number direction of rotation	
	A	B	C	SS	d	G	H	W	PP	d	G	H	W	min. rpm	max. rpm		clockwise	counter-clockwise
0140	62.1	68.3	122.8	P2	3/4"	M10	47.63	22.23	P2	3/4"	M10	47.63	22.23	500	3000	250		
0160	63.2	70.3	124.8	P3	1"	M10	52.37	26.19	P2	3/4"	M10	47.63	22.23	500	3400	250		
0190	64.7	73.3	127.8	P3	1"	M10	52.37	26.19	P2	3/4"	M10	47.63	22.23	500	3300	250		333 9112 180
0230	66.7	77.4	131.9	P3	1"	M10	52.37	26.19	P2	3/4"	M10	47.63	22.23	500	3300	250	333 9111 193	333 9112 177
0250	67.7	79.4	133.9	P4	1 1/4"	M10	58.72	30.17	P3	1"	M10	52.37	26.19	500	3100	250		333 9112 388
0280	69.2	82.4	136.9	P4	1 1/4"	M10	58.72	30.17	P3	1"	M10	52.37	26.19	500	3100	250	333 9111 669	333 9112 274
0330	71.7	87.5	142.0	P4	1 1/4"	M10	58.72	30.17	P3	1"	M10	52.37	26.19	500	3000	250		333 9112 374
0380	74.3	92.5	147.0	P4	1 1/4"	M10	58.72	30.17	P3	1"	M10	52.37	26.19	500	3000	250	333 9111 290	333 9112 412
0440	77.3	98.6	153.1	P4	1 1/4"	M10	58.72	30.17	P3	1"	M10	52.37	26.19	500	2800	225	333 9111 150	333 9112 346
0520	81.3	106.7	161.2	P5	1 1/2"	M12	69.82	35.71	P3	1"	M10	52.37	26.19	500	2700	190	333 9111 360	333 9112 357
0700	90.4	124.9	179.4	P5	1 1/2"	M12	69.82	35.71	P3	1"	M10	52.37	26.19	500	2300	165	333 9111 563	

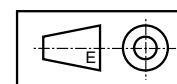

Dimensions (clockwise rotation shown)

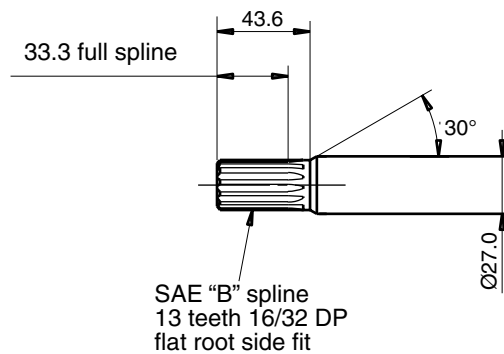
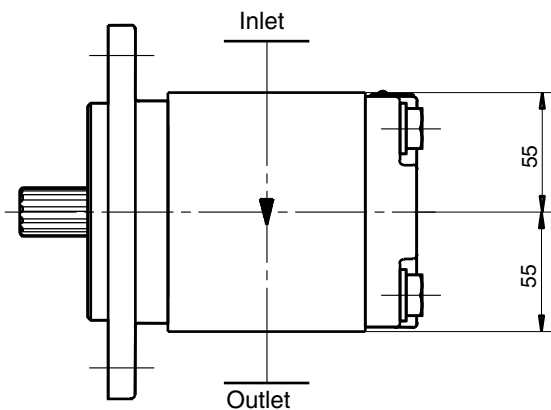
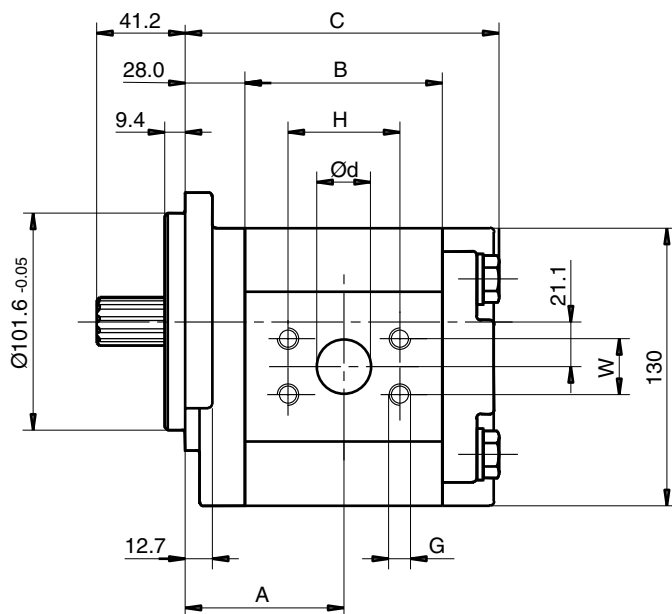

PI PGP-PGM UK.PMD RH



PGP517 A XXXX Y T1 D7 N SS PP B1 B1

“Y” = C (clockwise rotation)
 = A (counter-clockwise rotation)

Displacement XXXX	cm ³ /rev	Dimension			Inlet port			Outlet port			Speed of rotation		Working pressure max. bar	Order number direction of rotation			
		A	B	C	SS	d	D	G	PP	d	D	G		min. rpm	max. rpm	clockwise	counter-clockwise
0140	14.0	62.1	68.3	122.8	L3	27	51	M10	L2	19	40	M8	500	3400	250	333 9111 503	
0160	16.0	63.2	70.3	124.8	L3	27	51	M10	L2	19	40	M8	500	3400	250	333 9111 505	333 9112 430
0190	19.0	64.7	73.3	127.8	L3	27	51	M10	L2	19	40	M8	500	3300	250	333 9111 285	333 9112 212
0230	23.0	66.7	77.4	131.9	L3	27	51	M10	L2	19	40	M8	500	3300	250	333 9111 119	333 9112 213
0250	25.0	67.7	79.4	133.9	L3	27	51	M10	L2	19	40	M8	500	3100	250	333 9111 047	333 9112 068
0280	28.0	69.2	82.4	136.9	L3	27	51	M10	L2	19	40	M8	500	3100	250	333 9111 287	333 9112 214
0330	33.0	71.7	87.5	142.0	L3	27	51	M10	L2	19	40	M8	500	2600	250	333 9111 014	333 9112 035
0380	38.0	74.3	92.5	147.0	L3	27	51	M10	L2	19	40	M8	500	2300	250	333 9111 015	333 9112 036
0440	44.0	77.3	98.6	153.1	L3	27	51	M10	L2	19	40	M8	500	2000	220	333 9111 046	333 9112 040
0520	52.0	81.3	106.7	161.2	L3	27	51	M10	L2	19	40	M8	500	1700	200	333 9111 242	333 9112 215

Dimensions (clockwise rotation shown)

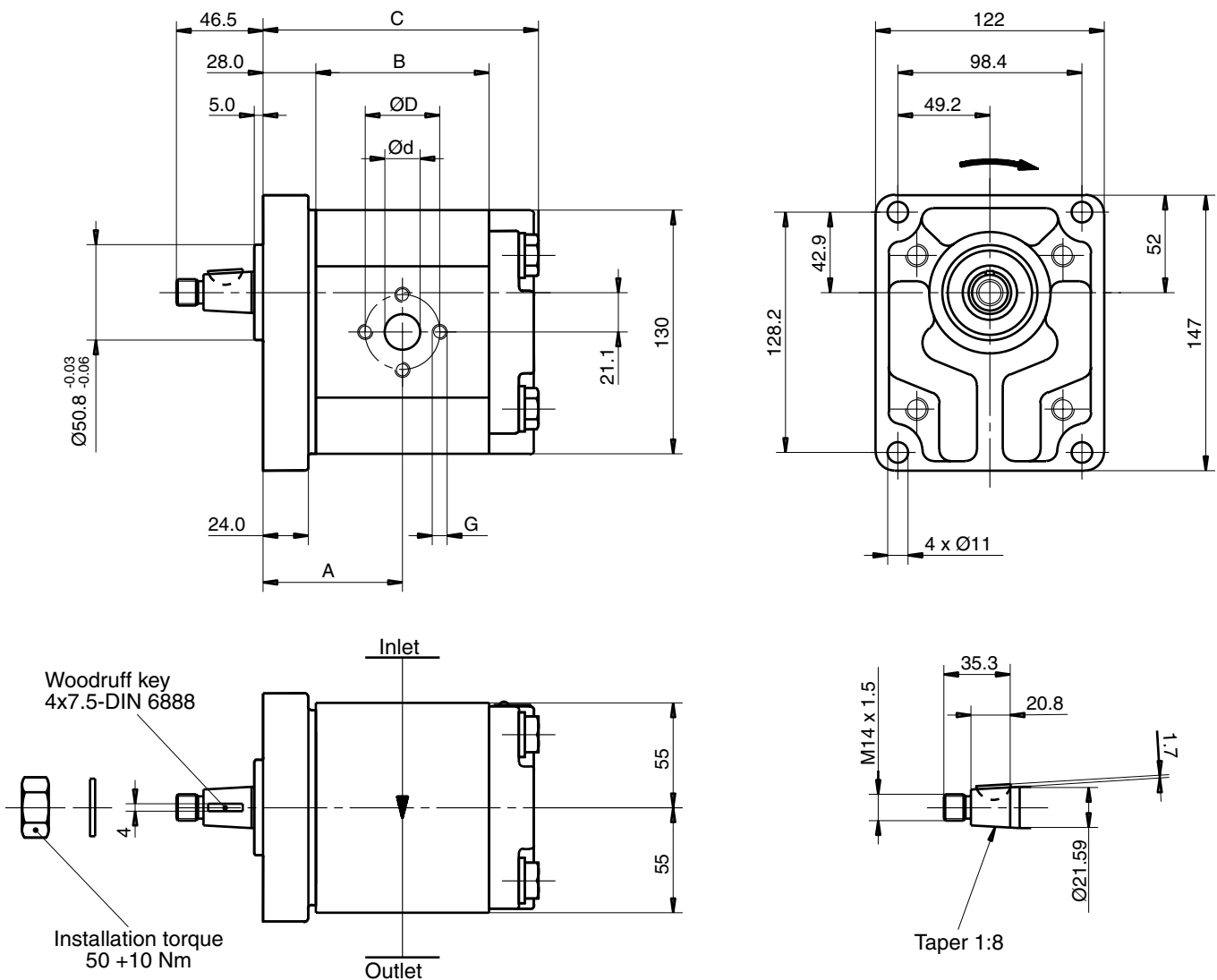
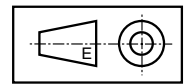

PI PGP-PGM UK.PMD RH



Code for multiple units

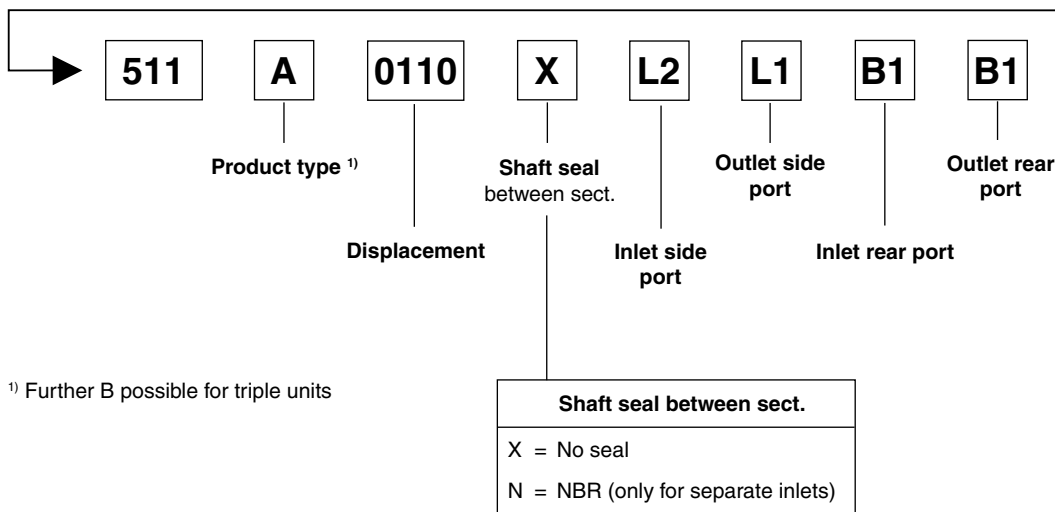
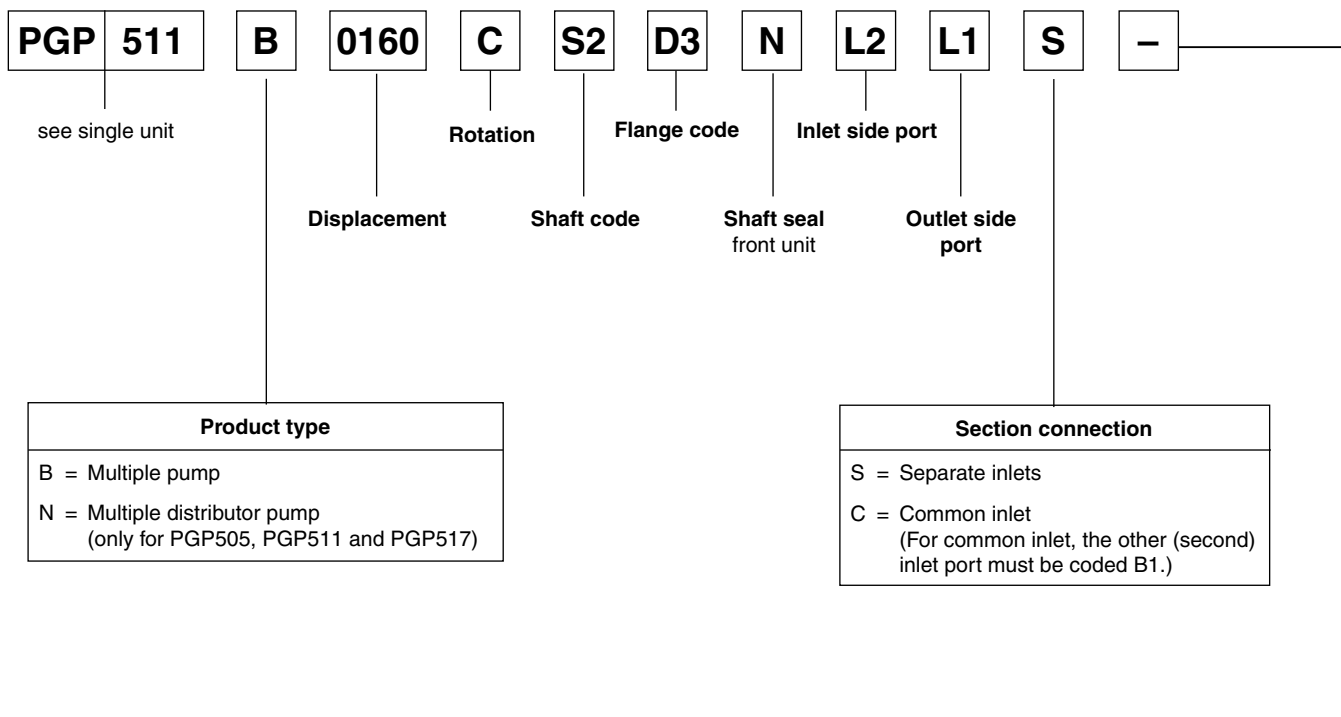

¹⁾ Further B possible for triple units

This coding system can be used for all pumps series 500.