

Suction Elements

Reservoir Equipment



Proven solutions for oil reservoir efficiency

A range of quality fluid power products for reservoir and system application

A high quality range of products designed to complete a reservoir installation including in-tank suction strainers and oil diffusers, metal and polyester in-line filters and drive couplings with nylon sleeve and sintered steel couplings. Inline check valves, single station gauge isolator valve and 63mm/100mm pressure gauges are also available.



Contact Information:

Parker Hannifin
Hydraulic Filter Division Europe

European Product Information Centre
Freephone: 00800 27 27 5374
(from AT, BE, CH, CZ, DE, EE, ES, FI, FR, IE, IT, PT, SE, SK, UK)
filtrationinfo@parker.com

www.parker.com/hfde

Product Features:

- In-tank suction strainers and oil diffusers.
- Metal and polyester in-line filters and drive couplings.
- Inline check valves.
- Gauge isolator valves and 63mm/100mm pressure gauges.

Suction Elements

Reservoir Equipment

Specification



Construction:

Stainless steel media 30% glass filled nylon head. Zintec centre tube. Polyurethane adhesives.

Maximum working temperature:

-30°C to 90°C.

Maximum clear element pressure drop:

0.03 bar.

Filtration media:

125 micron*.

Flow range:

15-500 l/min (for 30cst).

Bypass rating:

0.17 bar.

Mounting threads:

G¹/₂ up to G3.

* Non-standard elements are available to order. Consult Parker Filtration.

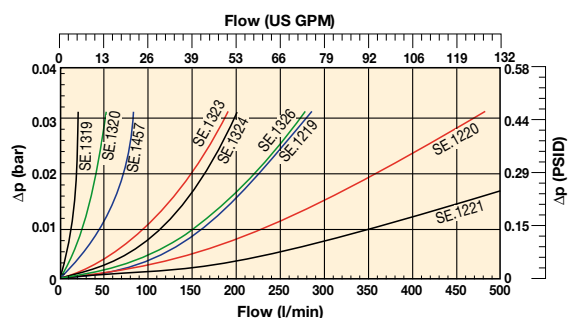

Installation - Suction Elements Without Bypass

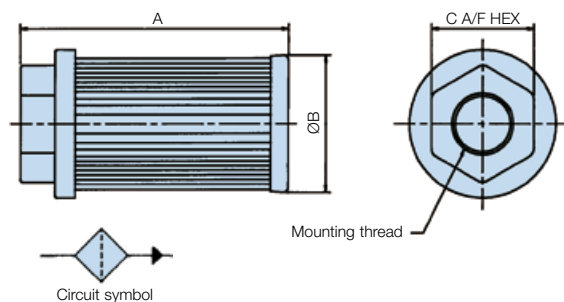

Installation - Suction Elements with Bypass

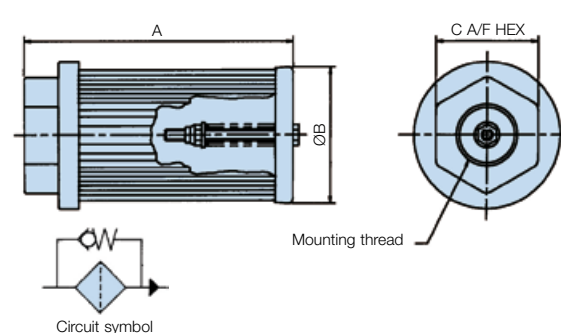

Ordering Information - Without Bypass

Standard products table

Part number	Supersedes	Flow l/min	Ports BSP	Micron rating	Dimensions (mm)			Weight	Bypass rating
					A	B	C		
SE75111110	SE.1319	15	1/2	125	105.5	46	36	0.08	N/A
SE75221110	SE.1320	25	3/4	125	109.5	64	46	0.15	N/A
SE75231210	SE.1457	50	1	125	139.5	64	55	0.17	N/A
SE75351210	SE.1323	95	1 1/2	125	140	86	65	0.28	N/A
SE75351310	SE.1324	130	1 1/2	125	200	86	65	0.33	N/A
SE75361410	SE.1326	180	2	125	260	86	75	0.40	N/A
SE75461210	SE.1219	225	2	125	150	150	70	0.64	N/A
SE75471310	SE.1220	350	2 1/2	125	212	150	90	0.72	N/A
SE75481410	SE.1221	500	3	125	272	150	100	0.92	N/A

Note 1: Part numbers featured with bold highlighted codes will ensure a 'standard' product selection.

Note 2: Alternate displayed part number selection will require you to contact Parker Filtration for availability.

Ordering Information - With Bypass

Standard products table

Part number	Supersedes	Flow l/min	Ports BSP	Micron rating	Dimensions (mm)			Weight	Bypass rating
					A	B	C		
SE75111111	SE.5100	15	1/2	125	105.5	46	36	0.08	0.17 bar
SE75221111	SE.5101	25	3/4	125	109.5	64	46	0.15	0.17 bar
SE75231211	SE.5102	50	1	125	139.5	64	55	0.17	0.17 bar
SE75351211	SE.5103	95	1 1/2	125	140	86	65	0.28	0.17 bar
SE75351311	SE.5104	130	1 1/2	125	200	86	65	0.33	0.17 bar
SE75361411	SE.5105	180	2	125	260	86	75	0.40	0.17 bar
SE75461211	SE.5106	225	2	125	150	150	70	0.64	0.17 bar
SE75471311	SE.5107	350	2 1/2	125	212	150	90	0.72	0.17 bar
SE75481411	SE.5108	500	3	125	272	150	100	0.92	0.17 bar

Note 1: Part numbers featured with bold highlighted codes will ensure a 'standard' product selection.

Note 2: Alternate displayed part number selection will require you to contact Parker Filtration for availability.

